

SPECIFICATIONS

CONFIGURATION	RACKABLE CHASSIS	STAND-ALONE
Technologies	White Light Polarization Interferometry (WLPI) Semiconductor Band Gap (SCBG)	
Sensors Compatibility	All Opsens Solutions WLPI sensors and SCBG-based sensors	
Number of Module	1 to 13 WLX-2(S) and/or GSX-2 modules 1 Control interface module (CSC-B or CSC-M module)	1 WLX-2(S) or GSX-2 module
Number of Channel	2 to 26 channels per chassis Up to 1,300 channels in multi-chassis configuration	2 channels
Sampling rate	WLX-2 module: up to 500 Hz WLX-2S module: up to 1,000 Hz GSX-2 module: up to 1,000 Hz	
Communication Interfaces	EtherCAT® and Ethernet Interface 10/100 Base-T	Ethernet Interface 10/100 Base-T and USB
Analog Outputs	0-5 V, ±5 V, 0-10 V, 0-20mA, 4-20 mA	
Dimensions	19" Rack, 4U (482.6mm x 307mm x 178mm)	210mm x 115mm x 42mm
Weight	Full: 9.4 Kg (0.35 Kg per module)	0.68 Kg
Input Voltage and Frequency	90 to 260 VAC ; 48 to 62 Hz	8 to 32 VDC
Power Consumption	Full: 70W (5W per module)	5W
Software	ServSens with (EtherCAT® and Ethernet Interface)	ServSens (with Ethernet) or LogSens (with USB)
ServSens Application	Embedded or on computer	On computer
Local Data Storage	SDHC (32Gb)	NA
Storage Temperature	-30°C to 65°C	
Ambient Operating Temperature	0°C to 45°C	
Ambient Relative Humidity	Maximum 95% non-condensing	

Mechanical Drawings (in mm)

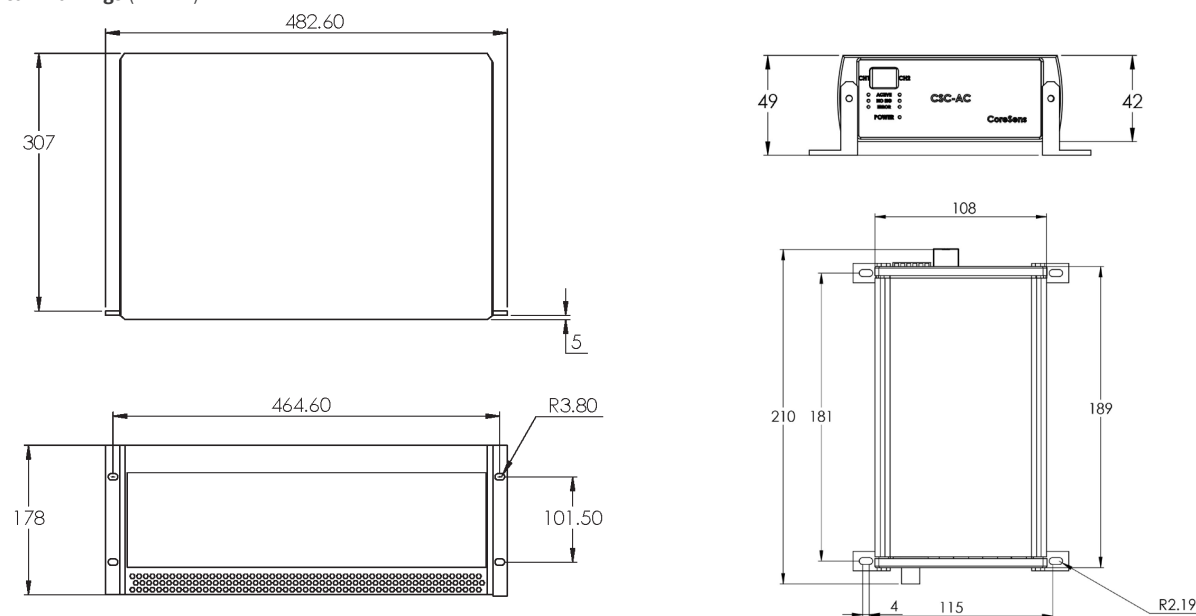

opSens Solutions

Enlightenment through smart measurements

CORESENS

SIGNAL CONDITIONER

DESIGNED FOR THE MOST DEMANDING APPLICATIONS REQUIRING HIGH-SPEED DETERMINISTIC MEASUREMENTS

- Scalable system with dual channel fiber optic measurement modules
- Available in multi-module rackmount chassis or single-module stand-alone unit
- Support both WLPI and SCBG-based technologies
- EtherCAT®, Ethernet and USB interfaces
- Embedded web server application for easy system configuration and control
- Internal data logging and storage
- Bluetooth remote communication (optional)



Precise and tailored to your needs, the CoreSens new generation of signal conditioner developed by Opsens Solutions offers high-speed measurements with deterministic synchronization over a large number of measurement channels. With its EtherCAT® interface, multiple CoreSens units can be grouped in single measurement system offering up to 1,300 measurement channels.

The CoreSens unit is built around dual-channel fiber optic measurement modules which are mounted in a rackmount chassis. The WLX-2(S) modules are used with Opsens Solutions WLPI-based technology fiber optic sensors for measuring temperature, pressure, strain or displacement. The GSX-2 modules are used with Opsens Solutions SCBG-based technology fiber optic temperature sensors (OTG sensors). Both type of modules can be mixed in a single chassis and each module has two fiber optic measurement channels each running at sampling rate up to 1,000 Hz and comes with two analog outputs.

EtherCAT® is registered trademark and patented technology, licensed by Beckhoff Automation GmbH, Germany.

opSens Solutions

Enlightenment through smart measurements

THE CORESENS SIGNAL CONDITIONER: THE OPTIMAL SOLUTION FOR HIGH-SPEED AND SYNCHRONISED MEASUREMENTS

VERSATILE, MODULAR AND SCALABLE

The CoreSens unit is the latest generation of Opsens Solutions' signal conditioners equipped with state-of-the-art technologies. It is a scalable and modular unit with dual-channel measurement modules that can be added as function of your needs.

Highly versatile, the CoreSens supports a broad range of fiber optic sensors and offers measurement sampling rate up to 1,000 Hz. The integrated EtherCAT® fieldbus and interface ensures a true deterministic synchronisation of the multi-channel measurements.

The CoreSens support two different dual-channel modules:

- **WLX-2(S)** for White Light Polarization Interferometry (WLPI) technology (Patent # US7,259,862) which provides accurate and reliable measurements of physical parameters such as temperature, strain, pressure and displacement
- **GSX-2** for SemiConductor BanGap (SCBG) technology for measuring fast temperature variations.

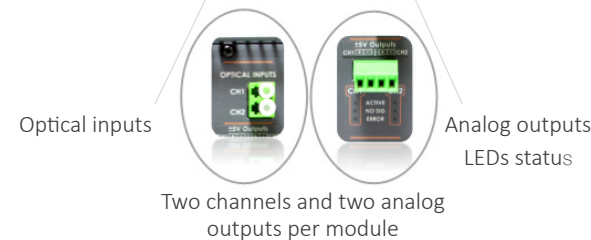

TAILORED TO YOUR NEEDS

The CoreSens is available in multi-module rackmount chassis configuration (up to thirteen WLX-2(S) and/or GSX-2 dual channel measurement modules per chassis) for great modularity. The Master EtherCAT® (CSC-M) or the Bridge EtherCAT® (CSC-B) control interface module can manage up to fifty CoreSens chassis to provide full control over a total of 1,300 measurement channels. A stand-alone unit configuration comprising a single WLX-2(S) or GSX-2 dual channel measurement module is also available.

RACKMOUNT SINGLE CHASSIS



RACKMOUNT MULTI-CHASSIS



STAND-ALONE UNIT



MULTI-SECTORIAL

- **Civil Engineering:** monitoring civil and geotechnical infrastructures (bridges, dams, tunnels, mines, buildings)
- **Military and aerospace:** testing, monitoring of aircraft components
- **Industrial:** automation and process control
- **Energy:** wind farm, nuclear environment, turbine instrumentation, high voltage areas
- **Oil and gas:** offshore platform, refining and storage applications

MULTIFUNCTIONAL

- Simultaneous and synchronised high-speed measurements of:
 - Temperature
 - Pressure
 - Strain
 - Displacement

CORESENS A FLEXIBLE INSTRUMENT

VERSATILE AND OPEN INTERFACES

For more flexibility, users can connect the CoreSens system to their own EtherCAT® network (with CSC-B module) or Ethernet network (with CSC-M module).

CoreSens open interface architecture enables users to develop and use their own application interface on EtherCAT® or Ethernet-based communication link with the CoreSens unit. SCPI-like commands for easy programming are supported with both interfaces.

EtherCAT® CAPABILITY

The EtherCAT® interface and protocol is the ultimate choice for true deterministic synchronisation of high-speed and multi-channel measurements.

Opsens Solutions is proud to offer this state-of-the-art real-time industrial fieldbus on Ethernet technology in all rackmount versions of the CoreSens products.

EtherCAT® is registered trademark and patented technology, licensed by Beckhoff Automation GmbH, Germany.

SERVSENS: FOR EASY CONFIGURATION AND DATA ACQUISITION

Opsens Solutions offers a simple and versatile web server application available with all CoreSens configurations. In the chassis configurations and with the CSC-M control unit module, the ServSens application runs in an embedded web server without the need to install any software on customer PC.

The ServSens application provides all the functionalities for system, module and sensor configuration and for real time data acquisition and storage.

SERVSENS: KEY FEATURES

- Configure multiple CoreSens units and modules
- Create and edit your sensor list
- Perform multi-channel data acquisition at full system speed (1,000 Hz on each channel)
- Store, retrieve, visualise and export acquired data seamlessly
- Perform system diagnostic and system firmware update

WEB SERVER APPLICATION - SERVSENS

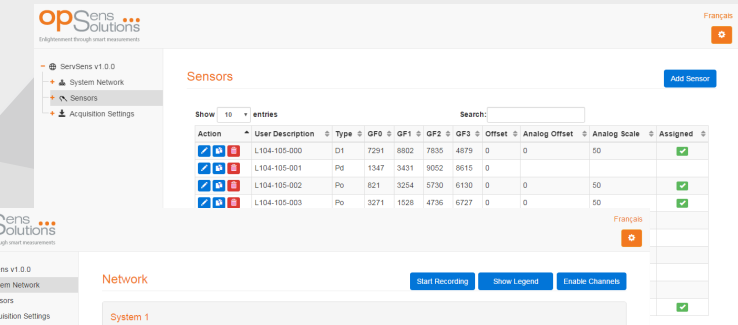

LogSENS: CoreSens Stand-alone

The LogSens software is provided with the CoreSens Stand-alone system for use with the USB interface. The LogSens provides all functionalities for the configuration of the system, the module and the sensors, as well as for the acquisition and storage of data in real time.

