

TURN ON  
3D TECHNOLOGY



UNIVERSAL,  
MOBILE 3D SCANNER



The ideal shape and color reproduction  
- perfect Digital Twin

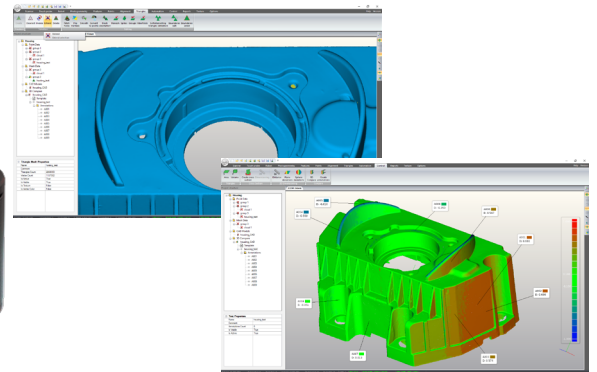

SMARTTECH3D ON is a universal 3D scanner that combines guaranteed metrological precision of measurement for quality control and documentation, with the possibility of realistic texture color mapping. Thanks to its small size, the device can be integrated with the cobot that automates the measurement, and at the same time serve as a mobile scanning head for on-site service at the customer's site.

### Metrological precision of mapping

High-class detectors that perform stereoscopic measurement assure effective noise elimination and the use of bi-directional fringe projection provides a better representation of the sharp edges of the measured objects. Thanks to the closed housing and carbon fiber support construction, the device is resistant to temperature changes and does not require calibration before each use. SMARTTECH3D ON measurement quality is confirmed according to VDI/VDE 2634 guidelines. The 3D scanner can be additionally certified by an independent accredited calibration laboratory on request.

### Multifunctional, advanced SMARTTECH3Dmeasure software

The SMARTTECH3Dmeasure software supplied with the system has been equipped with the basic tools needed for both reverse engineering and quality control. The whole process of measuring and creating a report can be individualized and automated according to the user's requirements. SMARTTECH3Dmeasure features simple creation of reports and enables achieving a full-color digital twin of the measured object for both documentation and visualization.



The small dimensions of the device allow  
to transport the 3D scanner as a hand  
luggage during flights.

# SMARTTECH3D Quality Station

## One 3D scanner, many possibilities

SMARTTECH3D ON can be equipped with a standard rotary table of various capacities from 15 kg up to 300 kg. The system can also be integrated with a rotary-tilting stage, creating a dedicated solution for automatic quality control - Quality Station.

## Quality Control in one step

The Quality Station measurement system is a comprehensive solution for quality control of geometrically complex objects. Thanks to the integration of the optical 3D scanner SMARTTECH3D ON with the tilt-rotary table, the device allows automatic, precise measurement of the object. The SMARTTECH3Dmeasure dedicated software, allows instant comparison of the measured part with the reference CAD model and generation of an individual control report in PDF format. Such a hardware-software combination enables the user to fully automate the entire inspection process from one mounting position without the need for operator interaction.

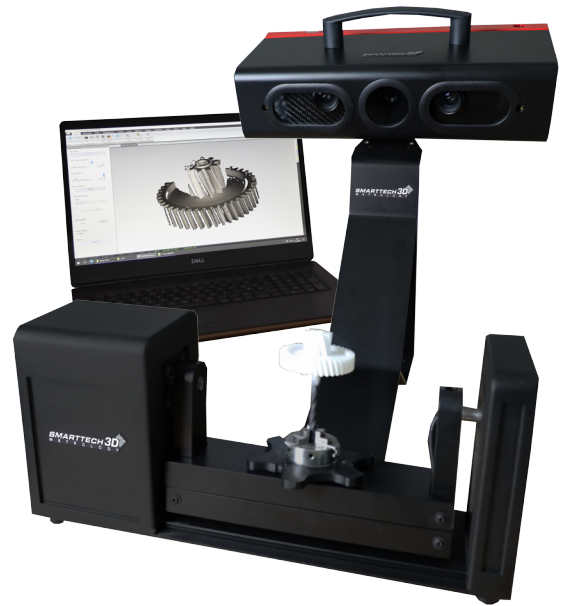

## TECHNICAL SPECIFICATION

### SMARTTECH3D ON:

Model	1.5-1.5 MP		
Scanning Technology	SMARTLED white/green/blue		
3d scan with colour	OPTION		
Detector resolution	1,5MP	1,5MP	1,5MP
Measuring field* [mm <sup>2</sup> ]	150x100	200x133	300x200
Measuring depth* [mm]	75	90	120
Sampling* [pts/mm <sup>2</sup> ]	100	58	25

Model	6-6 MP		
Scanning Technology	SMARTLED white/green/blue		
3d scan with colour	OPTION		
Detector resolution	6MP	6MP	6MP
Measuring field* [mm <sup>2</sup> ]	150x100	200x133	300x200
Measuring depth* [mm]	75	90	120
Sampling* [pts/mm <sup>2</sup> ]	410	230	100

Model	12-12 MP	
Scanning Technology	SMARTLED white/green/blue	
3d scan with colour	OPTION	
Detector resolution	12MP	12MP
Measuring field* [mm <sup>2</sup> ]	200x150	300x225
Measuring depth* [mm]	90	120
Sampling* [pts/mm <sup>2</sup> ]	402	178

\* +/- 10% value

### Additional Accessories:

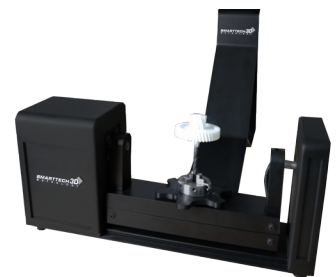

Rotary-tilting stage



Automatic Rotary Stage:

- max load 15kg, diameter 200mm
- max load 80kg, diameter 500mm
- max load 300kg, diameter 500mm

Some of our customers:

